

## ABT-VS-LP-36-TS

### Product Description

These premium touchscreen refrigerators offer precise temperature control and advanced digital monitoring, ideal for clinical and research settings. They feature variable speed compressor technology for exceptional performance and energy efficiency. Experience an intuitive color touchscreen controller, offering multi-layered access and data logging capabilities. Protect your samples with forced draft air circulation and customizable alarms with remote contacts. Also enjoy the benefit of natural, hydrocarbon refrigerants for energy savings and a greener laboratory footprint. This refrigerator is constructed with durable powder-coated steel, self-closing glass doors, keyed access locks, LED interior lighting, and adjustable interior shelving. Also included is a comprehensive 3-year parts and labor warranty with a generous 7-year compressor warranty to protect your investment. With these refrigerators, you'll increase performance and maximize efficiency in your lab.

### Images



### Certifications



### General Description and Application

Storage capacity (cu. ft)	36 Cu. Ft.
Door	Two (2) swing glass doors, self-closing, one right hinged, one left hinged magnetic door gasket
Shelves	Eight (8) adjustable shelves (adjustable in 1/2" increments)
Mounting and Installation	Swivel casters - locking front casters
Interior lighting	LED interior lights are safety shielded and switch controlled
Airflow Management	Forced draft air circulation, patented air flow technology
External probe access	3/4" probe access port on rear wall
Insulation	Cabinet is foamed-in-place with EPA compliant high-density urethane foam
Exterior materials	White powder coated steel
Access control	Keyed door lock
General warranty	Three (3) year parts and labor warranty
Compressor warranty	Seven (7) year compressor warranty
Product Weight (lbs)	355
Shipping Weight (lbs)	405
Rated Amperage	3 Amps
Power Plug/Power Cord	NEMA 5-15 plug
Facility Electrical Requirement	110 - 120V AC, 15A breaker, NEMA 5-15 receptacle
Agency Listing and Certification	ETL, C-ETL listed. Meets or exceeds ENERGY STAR® v2.0 for Laboratory Refrigerators. Official listing pending - see energystar.gov

### Performance

Maximum temperature variation (Cabinet air)	+/- 1° C
Stability (Simulator ballast)	+/- 0.2° C
Adjustable Temperature Range	2° C to 15° C
Stability (Simulator bag)	Non-applicable
Energy Consumption (KWh/day)	2.5 KWh/day *meets ENERGY STAR® v2.0 for Laboratory Refrigerators
Average Heat Rejection (BTU/hr)	630 BTU/h
Noise Pressure Level (dBA)	40 dBA or less installed
Pull down time to nominal operating temp	< 40 min (empty)

### Performance Note

Max temperature variation based on an empty chamber at steady state using 15 bare (unweighted) thermocouple probes. Product loading, door openings, and ambient conditions will affect performance. Stability of simulator ballast based on bottle probe provided with the unit located center of empty chamber at steady state, no door openings

Refrigeration System	
Compressor	Hermetic, variable speed
Refrigerant	EPA SNAP compliant R600a Isobutane (Hydrocarbon natural refrigerant)
Condenser	Tube and grid, high efficiency fan forced air
Evaporator	Fin and tube, high efficiency fan forced air
Defrost	Cycle Defrost
Controller, Configuration, Alarms and Monitoring	
Controller technology	Microprocessor with color touchscreen (8in) input and display, C°/F° switchable, resolution is 0.1° C/0.2° F
Battery Backup	High capacity 12V battery for controller temperature and alarm display and logging only, no cooling active
Display technology	8" touchscreen featuring: security and access: multi-level password protection: user, supervisor, and admin roles for access and control. Advanced controls: customizable passwords/PINs: Ensures tailored access for your team. Calibration adjustments: fine-tune temperature offsets for precise measurements. visual and user interface: intuitive touch screen: pinch-to-zoom, scrollable graphs, and customizable display options. Adjustable display settings: screen brightness, real-time temperature comparison to alarm points, and selectable °C/°F display with 0.1°C/0.2°F resolution.
Data Transfer	Non-applicable
External alarm connection	Remote alarm contacts
Digital Communication	4-20mA Output
Alarms	Audible & Visual Alarms: customizable sounds and volumes; silent mode with visual persistence. Alarm delays: Adjustable settings for door, temperature, and power loss alarms to prevent nuisance alerts. Ring-back functionality. Audible alarms re-engage after a preset delay if the condition persists
Display Probe	Product simulator bottle with glass bead media
Disclaimers	Refrigerator requires a minimum 2" of clearance around back and sides of the unit for proper ventilation (more if next to heat rejecting equipment) - improper installation will void the warranty and will lead to temperature maintenance issues, overheating and possible failure

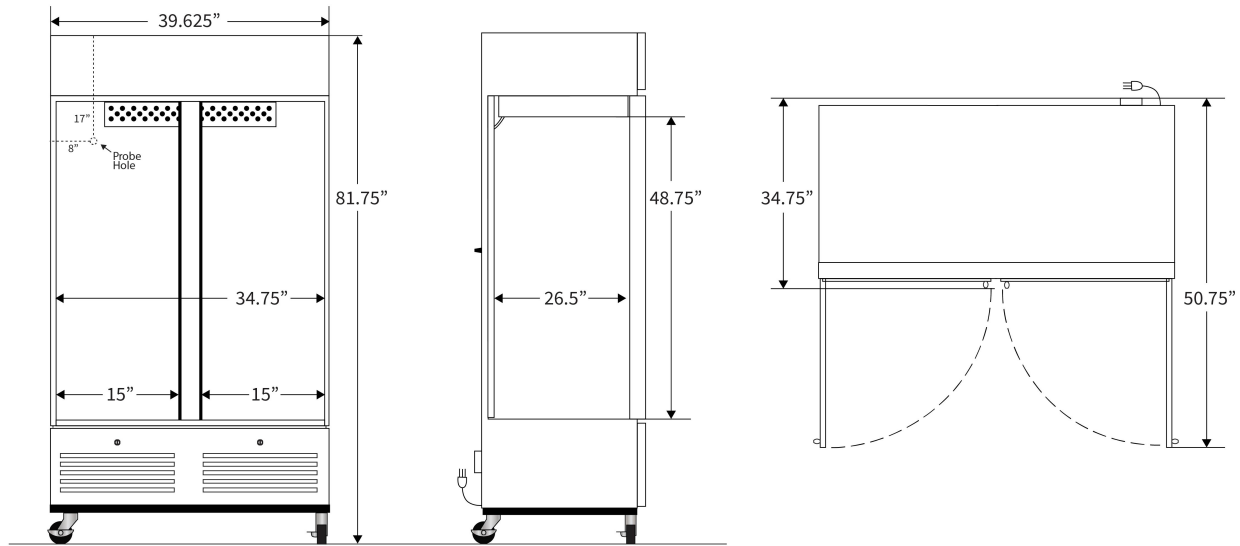

Contact		
Customer Service	800-648-4041 Option 3	<a href="mailto:customerservice@horizonscientific.com">customerservice@horizonscientific.com</a>
Technical Service	800-648-4041 Option 5, Parts Option 4	<a href="mailto:technicalservice@horizonscientific.com">technicalservice@horizonscientific.com</a>