

## ABT-HC-ERCS-30

### Product Description

This hazardous location refrigerator/freezer combo unit meets NFPA and OSHA guidelines for the safe storage of volatile materials in potentially hazardous work environments. This model is the ideal choice for industrial environments requiring strict safety protocols. It delivers 30 cubic feet of spacious storage and utilizes EPA SNAP compliant natural refrigerants for environmentally responsible operation. Powered by microprocessor temperature technology, this model delivers precise and stable temperature control.

Please note that this unit must be hardwired for safety. With low energy consumption and high safety standards, this model is a safe and efficient solution for hazardous laboratory locations and industrial settings.

### Images



### Certifications



### General Description and Application

Storage capacity (cu. ft)	30 Cu. Ft. (25 Cu. Ft. Refrigerator/5 Cu. Ft. Freezer)
Door	One (1) solid swing, right hinged; stainless steel door handle; magnetic door gasket
Interior	One (1) inner door (Freezer)
Shelves	Three (3) adjustable wire shelves (Refrigerator)
Mounting and Installation	Leveling legs
External probe access	One (1) 3/4" probe access port on rear wall
Insulation	EPA compliant high density urethane foam
Exterior materials	Powder coated steel
Access control	Keyed door lock
General warranty	Two (2) year parts and labor warranty
Compressor warranty	Five (5) year compressor parts warranty
Product Weight (lbs)	353
Shipping Weight (lbs)	383
Rated Amperage	3 Amps
Power Plug/Power Cord	Power cord not included, final power connections must be hardwired to meet local codes
Facility Electrical Requirement	110 - 120V AC, 15A breaker
Agency Listing and Certification	UL listed per UL 60335-1 and UL 60335-2-89 standards; c UL listed per CSA C22.2 No. 120 standard. Meets NFPA and OSHA guidelines for hazardous locations, Class 1 Division II, Groups C&D

### Performance

Freezer temperature range	-15°C to -20°C
Freezer Maximum temperature variation	+/- 4.5°C
Refrigerator Maximum temperature variation	+/- 3.5°C
Refrigerator temperature range	0°C to 10°C
Pull down time to nominal operating temp	150 min (empty)
Energy Consumption (kWh/day)	4 kWh/day
Average Heat Rejection (BTU/hr)	570 BTU/hr

Refrigeration System	
Compressor	Hermetic, variable speed
Refrigerant	EPA SNAP compliant R290 propane
Condenser	Static - exterior walls of cabinet with auxiliary fan
Evaporator	Evaporator shelves
Defrost	Manual defrost

Controller, Configuration, Alarms and Monitoring	
Controller technology	ATEX rated Microprocessor temperature controller
Battery Backup	Non-applicable
External alarm connection	Remote alarm contacts
Alarms	Audible and visual high/low-temperature alarms (freezer only), door ajar alarm, remote alarm contacts

**Disclaimers**

Defrosting of the unit will need to be performed periodically to prevent severe ice build-up and to ensure proper temperature control. Refrigerator temperatures are impacted by the freezer temperature, especially at coldest freezer settings. Indoor use only, +18° C to +26° C (+65° F to +78° F), <70% RH. Specifications are subject to change. Equipment requires 4" of clearance around back and sides of the unit for proper ventilation – improper installation will void the warranty and will lead to temperature maintenance issues, overheating and possible failure.

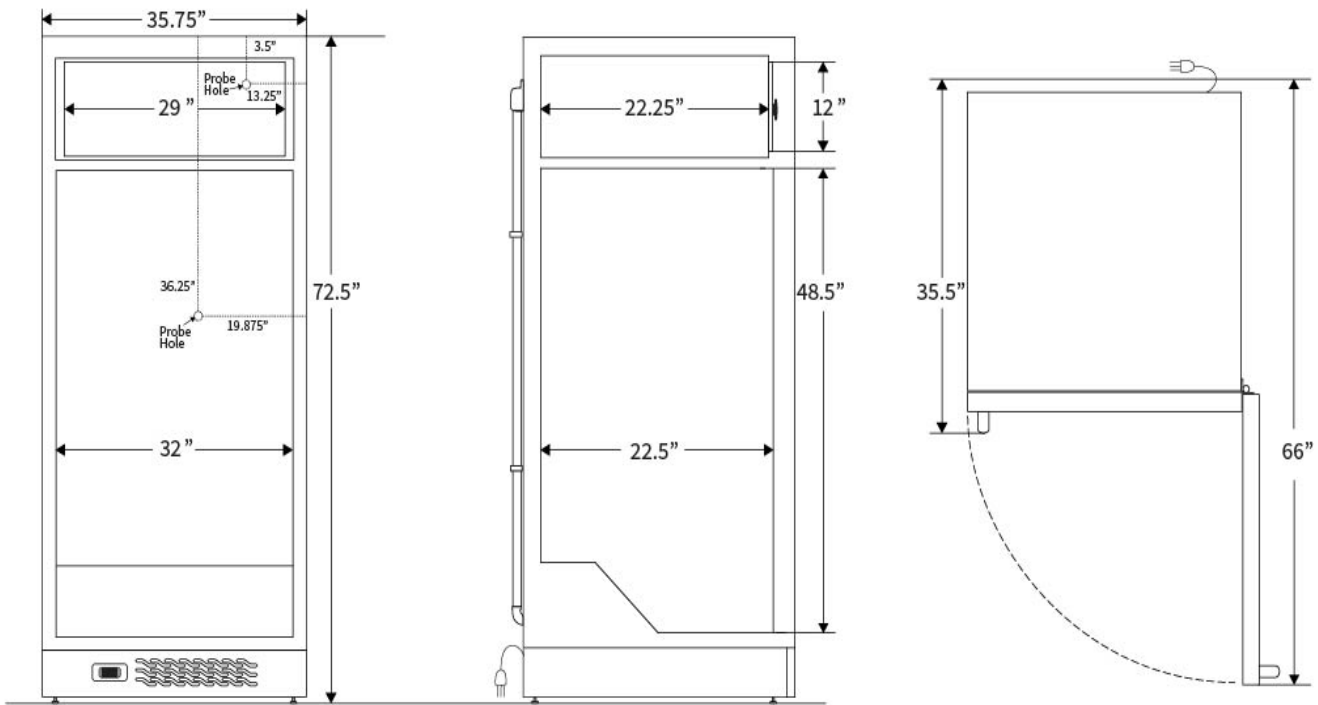

Contact		
Customer Service	800-648-4041 Option 3	<a href="mailto:customerservice@horizonscientific.com">customerservice@horizonscientific.com</a>
Technical Service	800-648-4041 Option 5, Parts Option 4	<a href="mailto:technicalservice@horizonscientific.com">technicalservice@horizonscientific.com</a>

